



Heriot-Watt University
Research Gateway

Transient analysis of a hybrid microgrid system

Citation for published version:

Adamopoulou, A, Fruh, W-G, Hatzia Apostolou, A & Samarakou, M 2012, Transient analysis of a hybrid microgrid system. in *Recent Advances in Energy, Environment and Economic Development*. WSEAS Press, pp. 128, Conference on Development, Energy, Environment, Economics, Paris, France, 2/12/12. <<http://www.wseas.us/e-library/conferences/2012/Paris/DEEE/DEEE-18.pdf>>

Link:

[Link to publication record in Heriot-Watt Research Portal](#)

Document Version:

Early version, also known as pre-print

Published In:

Recent Advances in Energy, Environment and Economic Development

Publisher Rights Statement:

I assume it is open access because I could download the final paper from the given website without problems

General rights

Copyright for the publications made accessible via Heriot-Watt Research Portal is retained by the author(s) and / or other copyright owners and it is a condition of accessing these publications that users recognise and abide by the legal requirements associated with these rights.

Take down policy

Heriot-Watt University has made every reasonable effort to ensure that the content in Heriot-Watt Research Portal complies with UK legislation. If you believe that the public display of this file breaches copyright please contact open.access@hw.ac.uk providing details, and we will remove access to the work immediately and investigate your claim.

Transient analysis of a hybrid microgrid system

Anastasia Adamopoulou
School of Engineering and Physical Sciences
Heriot–Watt University
EH14 4AS Edinburgh
Scotland, United Kingdom
adam@teiath.gr

Antonis Hatziapostolou
Department of Energy Technology, School of Technological Applications
Technological Educational Institute of Athens
Ag.Spyridonos 12210 Egaleo
Greece
ahatzi@teiath.gr

Wolf G. Früh
School of Engineering and Physical Sciences
Heriot–Watt University
EH14 4AS Edinburgh
Scotland, United Kingdom
W.G.Fruh@hw.ac.uk

Maria Samarakou
Department of Energy Technology, School of Technological Applications
Technological Educational Institute of Athens
Ag.Spyridonos 12210 Egaleo
Greece
marsam@teiath.gr

Abstract: - The penetration of Distributed Energy Resources in power generation has increased considerably during the last two decades. Low voltage grids are configured as microgrids in which the most common energy resources are photovoltaic systems and wind turbines, usually complemented by energy storage and/or backup generation. This paper presents the behavior of two microgrid systems in islanding mode. The first system consisted of a wind turbine, a diesel generator and a load, while the second system consists of the same components as the first system but a PV – battery system with an inverter is also inserted. The voltage and frequency characteristics of both scenarios are being examined. The main findings indicate that an absence of energy storage, such as a battery, leads to excessive backup generation capacity requirements, while the presence of an inverter after connecting the PV–battery unit has a strong effect on the power quality.

Key-Words: - Microgrid, Photovoltaic (PV), Wind turbine (WT), Diesel generator, Computer aided simulation

1 Introduction

Compared to conventional power systems, microgrids appear to be the most promising power system configuration as it has clear economic and environmental benefits. The appropriate design of microgrids is a multivariable process which should be based on the precise consideration of numerous case-specific economic and technical aspects. Microgrids address technical concerns and also

fulfill the necessity of growing deployment of renewable energy sources which, as distributed power generation (DG) technologies, offer power quality and reliability to meet the increasing sustainable electricity demand. Meeting the energy demands of consumers is vital for the adoption of microgrid systems, as consumers are accustomed to uninterrupted and reliable electricity supply. The growing requirements for the energy services provided by electricity will be met by using an

appropriate combination of methodologies, technologies, and approaches. After an examination of the electricity demand growth problem, microgrids are indicated as well suited players in the future evolution of energy service provision. The defining characteristic of a microgrid is that it is designed to be able to operate autonomously from the larger national grid, the “macrogrid”. When the macrogrid is unable to provide electricity to the consumers within the microgrid, its own generators will be able to cater for the entire energy demand of microgrid consumers [1-4]. DG can help in the reduction of transmission losses and congestion related problems which plague macrogrid systems, while encouraging the penetration of renewable energy sources and combined heat and power (CHP) technologies [5].

The output of the distributed energy resources can be direct current (DC) or alternating current (AC), and it is necessary to be converted to a specific AC in order to connect to the utility grid. Wind Turbine (WT) systems are very popular, especially connected to high Voltage grids. Alongside the established integration of wind turbines into high voltage grids, there is an increasing trend for utilizing WT as part of a low voltage grid. Also, grid-connected photovoltaic (PV) systems become popular due to the ability of immediate utilization and relatively high performance and efficiency [6, 7].

For grid-connected microgrids, control and protection during disconnections and/or faults is a major concern, especially since protection measures may be ineffective against quick transient phenomena [8]. Design on interfacing control strategies in DG units has investigated the nature of their interactions with the system and other DG units [9] or the impacts of controls in grid connected and islanding mode, such as a voltage control strategy for inverter-based DG units [10]. The proposed by [10] technique can be used in both modes: grid-connected and autonomous. In addition, this technique can be used to provide smooth transition from grid-connected to autonomous modes. However, it cannot be used to inject maximum power from DG units.

In this study, the dynamic behavior of two microgrids during an islanding event, incorporating PV, WT and a diesel generator is analyzed. The proposed modeling is implemented in MatLab/SimPowerSystems. This design is basically performed using the SimPowerSystems block models to construct an actual life-like grid. Simulations are executed for the investigation of the various effects on the power systems, the evaluation

of the microgrid stability and the analysis of the overall system performance.

The main objective of this study is to investigate the backup-generation required to meet the demand at the required power quality following the islanding of the microgrid, that is, the disconnection of an initially stable and grid-connected microgrid to a state where the distributed energy resources alone have to supply the load.

2. Microgrid Configuration

The building blocks of the microgrid system examined here are a wind turbine generator (WT), a PV–battery–inverter system, a diesel generator and a primary load, all connected to a common AC bus. These components are being used to configure two microgrids, one consisting of a WT, a diesel generator and a load, while the second configuration consisted of a WT, a PV–battery unit, diesel generator, and the load. The two configurations are being displayed in Fig. 1.

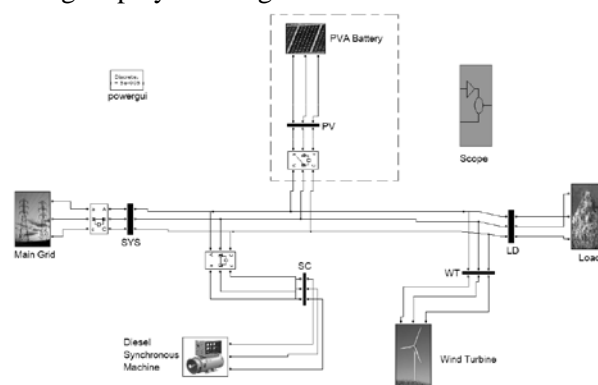

Fig. 1: Schematic diagram of the two microgrid systems examined.

As the main objective of this study is to investigate the required backup-generation, the load, WT, and PV–battery are being kept operating at their design point while the generating capacity of the diesel generator varies from 30kVA to 1MVA. The transient behavior of the microsystem is simulated following an islanding event to investigate which level of diesel generation is required to maintain the operation of the microgrid and to analyze the power quality during the islanding.

In both configurations, the load is a passive 200kW load and the WT has an installed capacity of 275kW. The PV– battery unit in the second configuration has a maximum power output of 100kVA at 380V at reference operating conditions of a PV array temperature of 25°C and light intensity of 1000W/m². At rated values of wind speed and reference operating values of solar

radiation, the diesel generator is not required and shuts down. In this mode, the diesel generator is used as a synchronous condenser and its excitation system controls the grid voltage at its nominal value. When the energy production from the WT and the PV fails to cover the demand, the diesel engine is restarted to meet the shortfall in the power. In order to model the system, this study is using the Matlab–Simulink–SimPower module. In general, a model can be used to study the performance of any hybrid power system. By using SimPower for other renewable energy sources as well, dynamic operation and control system strategies can be easily incorporated into the existing hybrid electric power system model to study the overall performance of the system. The simulations investigate the dynamic transient response of the PV inverter, the WT generator and the diesel generator. The simulation results can then be used to design a comprehensive control system and predict the power system impacts of integrating a PV array, a WT and a diesel generator.

The models developed to simulate the WT, PV – battery bank – inverter and diesel generators are generic [11, 12] and able to give accurate results without having to specify the dynamics of any particular device. In order to examine the dynamic behavior of the whole islanded system, models for the PV – battery bank – inverter were specified. A 3-leg inverter for 3-phase conversion with 6 MOSFETs is used as an inverter; additionally a control unit generates digital pulses to drive the MOSFETs at 3KHz. The pulse generator uses the Pulse Width Modulation (PWM) technique. The load voltage is being regulated at 1 PU (380Vrms) by a PI voltage regulator using abc to dq and dq to abc transformations. The first output of the voltage regulator is a vector containing the three modulating signals used by the PWM generator to generate the 6 MOSFET pulses. The power transfer between the inverter DC source and AC source is achieved by controlling the phase angle (δ) and magnitude of the inverter output voltage. Under normal operational conditions, the inverter generates an output voltage which should be kept synchronized with the voltage of the power system [11].

3 Simulation Results and Discussion

3.1 Model configurations

Throughout the simulations the load is a passive 200kW RLC load, the WT provides 275kW and, for the second configuration, the PV arrays – battery bank system at maximum power provide 100kVA at

380V. Because the load configuration is RLC, there are conductive currents between the load and the motor of the WT. Consequently the WT alone would not be sufficient to maintain the required power, even though its installed capacity exceeds that of the load. Both microgrid configurations are being tested for diesel generator capacities of 30, 100, 300 and 1000 kVA, respectively.

Each model is run in two stages. The first stage runs in grid-connected mode to establish a stable and equilibrated operation. The simulation of the first stage runs for 3s for the system to stabilize and the final state of the model is being used as initial state of the next simulation. In the second stage, the microgrid is initially interconnected with the main network for 0.3s and then the microgrid is being transferred to islanded mode.

The response of the microgrid to the islanding is then analyzed in terms of voltage level, active power, reactive power and the frequency spectrum of the voltage signal. The spectral analysis of the voltage signal provides a measure of the Total Harmonic Distortion (THD) as an indication of the power quality.

$$THD = (P - P_1)/P_1 \quad (1)$$

Where P is the total power and P1 the power in the fundamental (50Hz).

When using the voltage, THD is also given by equation 2.

$$THD = \left(\sum_{i=2}^{\infty} V_i^2 \right) / V_1^2 \quad (2)$$

3.2 Configuration 1 (without PV – battery unit)

In this section, the results of the islanding of the microgrid with the WT and diesel generator are presented.

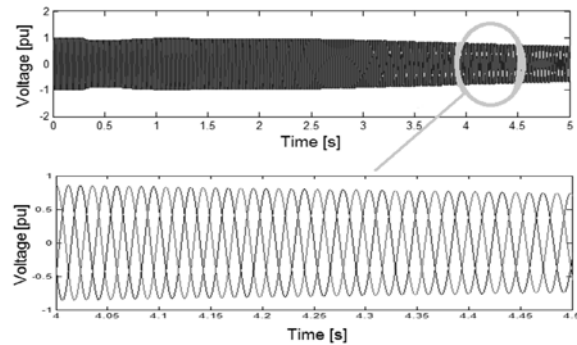

Fig. 2: Details of Voltage in the 1st microgrid with 30KVA diesel generator. Upper panel: the full 5s simulation, lower panel: a 0.5s detail.

A parametric study with diesel generators of various sizes is performed in order to find the generator's optimum size for the microgrid. With a diesel generator rated at 30kVA, the microgrid works satisfactory for the first 2.5s but beyond that time the values of both the voltage and the current of the microgrid decrease (Fig. 2 - 3).

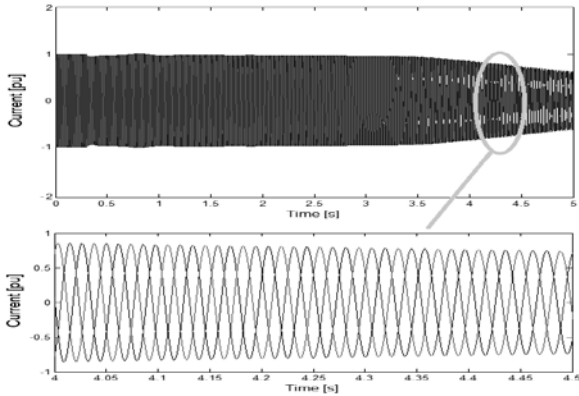

Fig. 3: Details of current in 1st scenario with 30KVA diesel generator

When the diesel generator capacity is increased to 100kVA, the microgrid works satisfactory for a longer period of time (almost 4.5s), after which period however it also displays decay (Fig. 4).

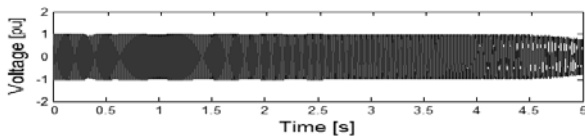

Fig. 4: Voltage in 1st scenarios with 100KVA diesel generator

As the size of the diesel generator is increased, the microgrid progressively works satisfactorily for longer periods (22% in 300kVA) (Fig. 5).

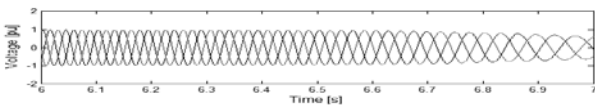

Fig. 5: Voltage 1st scenarios with 300KVA diesel generator

For each of the previous cases there is no balance between the active and reactive power, the lack of which is instigating the microgrid decay. When the diesel generator capacity is increased to 1000kVA, the grid is stabilized and operates without any problem (Fig. 6).

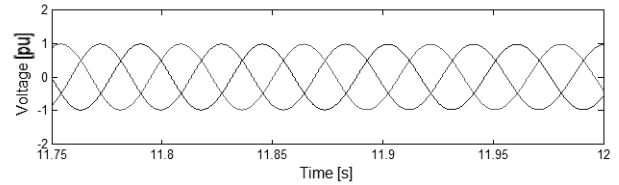

Fig. 6: Voltage 1st scenarios with 1MVA diesel generator

However, the WT penetration becomes less than 30% of the diesel generator's installed capacity and the actual load is only 20% of the diesel generator capacity or 17% of the total installed capacity. Such a configuration is evidently unacceptable for economic reasons.

The behavior of the microgrid with the 1000kVA diesel generator is satisfactory, with the voltage of WT converged to nominal operation voltage (380V) of the main grid (Fig. 7, in PU).

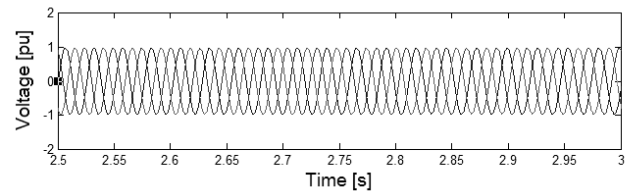

Fig. 7: Voltage of WT in PU

The active and reactive powers of the system are presented in Fig. 8. The reactive power is zero during the course of the simulation, while the active power is perturbed by around 20% during the islanding event and requires around 3s to be stabilized and reintroduce acceptable operating conditions.

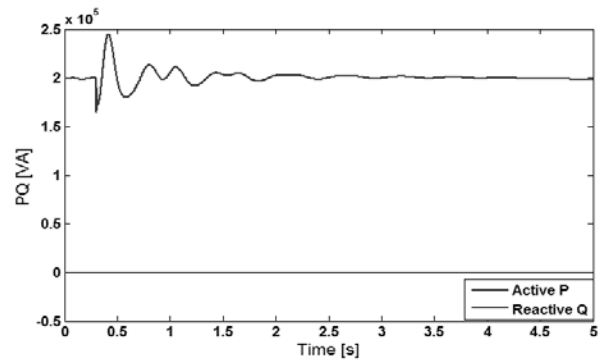

Fig. 8: Active and Reactive Power of Load

An indicator of the grid robustness in terms of how long the voltage is maintained at $PU \sim 1$ is given in table 1. The onset of decay (T_s) is defined as how many seconds the power is maintained at $PU > 0.95$. This information is also being presented in Fig. 9 as a decay rate ($1/T_s$), normalized by the grid frequency ($\tau = 50\text{Hz}/T_s$), plotted against the relative contribution of the wind generator compared to the

total generation capacity (wind & diesel) within the microgrid.

Table 1: Grid robustness

Diesel generator (kVA)	30	100	300	1000
Onset of decay (PU max = 0.95), T_s (s)	2.5	4.5	5.5	> 12
$1/T_s$ (Hz)	0.4	0.22	0.18	< 0.08

Fig. 9 shows that the grid appears stable when the wind generator operates at 20% capacity but stability progressively deteriorates as wind becomes a major part of the generating capacity.

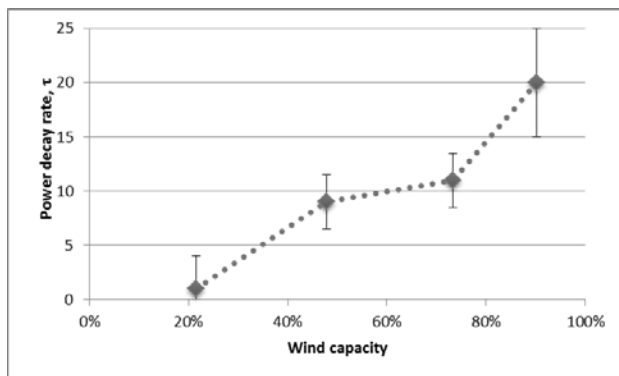

Fig. 9: Grid decay rate

3.3 Configuration 2 (with PV – battery unit)

In the second scenario the diesel generator is maintained at 100kVA but now the microgrid includes a PV – battery bank – inverter of 100kVA, resulting to a combined installed capacity of 375kW. With this configuration the microgrid is stabilized within the first second. Fig. 10 reveals that the insertion of a 100kVA PV – battery unit is sufficient to preserve the voltage level of the microgrid even with the use of a moderate diesel generator. However, careful inspection of Fig.10 also displays that the wave form of the voltage is far from pure sinusoidal and will have a significant contribution of higher harmonics.

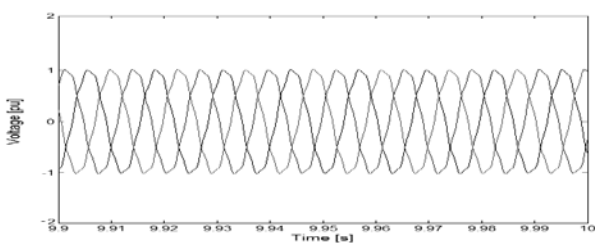

Fig. 10: Voltage 2nd scenarios with 100KVA diesel generator and 100KVA battery

The Total Harmonic Distortion (THD) is the most common indicator to determine the quality of AC waveforms. The harmonic computations are based on a standard Fast Fourier Transformation (FFT) technique. The voltage THD factor of the first scenario is 2.68%, which is considered relatively low according to the recommended values for acceptable harmonic distortion of IEEE Std 519 [13] and the contribution of higher harmonics decreases rapidly as shown in Fig. 11. On the other hand, the THD factor of the second scenario is substantially higher, reaching 14.95% (Fig. 12).

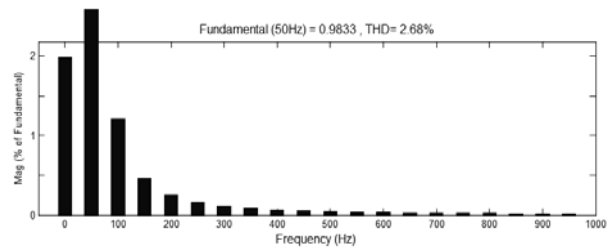
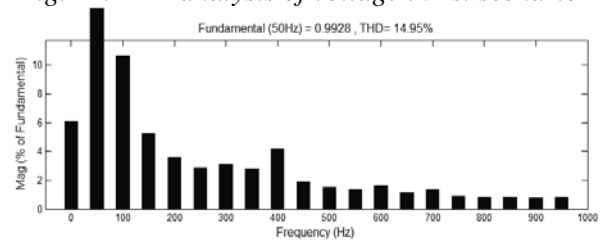
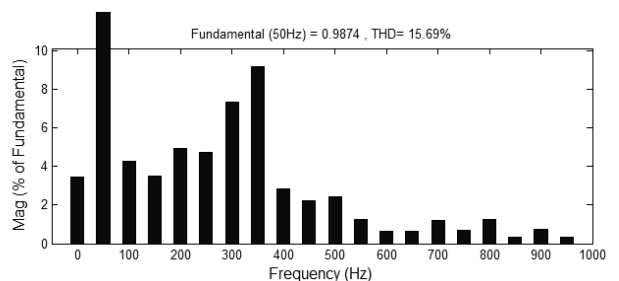

Fig. 11: FFT analysis of voltage in 1st scenario



The same figure reveals that all higher harmonics have a higher contribution to the power and that certain higher harmonics, in particular the second at 100Hz and the eighth at 400Hz, are significantly enhanced. The current spectrum, presented in Fig. 13, is even more distorted than the voltage spectrum, with the THD factor reaching 15.69% and displaying significant enhancement of all odd harmonics.



It is possible that these higher order harmonics are being caused by the inverter. To reduce the harmonics in the output voltage (and therefore the THD), it is necessary to implement a better filter in

the PV array - battery inverter. The harmonic voltages change when the microgrid switches to islanded mode. It follows that while the microgrid operates under islanded mode, it is much weaker and more sensitive to disturbances. This results to the generation of much higher harmonic voltages due to possible distorting loads.

4 Conclusion

The results demonstrate that the presence of a diesel generator enhances the performance of the electric grid by improving the voltage profile. The diesel generator improves the grid by ensuring the quality of figures which are necessary for the satisfactory operation of the grid, such as the voltage and frequency. Furthermore, the diesel generator also corrects the power factor.

The comparison of the two microgrid systems analyzed here suggests two conclusions. It would appear that a microgrid which contains distributed generators (e.g. wind turbines) but no energy storage requires a very high level of backup generation to maintain operational voltage levels during islanding events. In order to render a grid-connected microgrid consisting of a load and a matching wind turbine stable, the required diesel generator capacity to maintain satisfactory voltage level is several times higher than the power demand of the load.

The addition of a PV – battery with a power rating half of the rated load was sufficient to reduce the requisite diesel generator capacity significantly, considerably lower than the maximum rated load. However, as the energy storage was linked to the microgrid through an inverter, power quality became an issue. While the microgrid with only AC components displayed a THD of 2.7%, the addition of the inverter attaching the PV – battery setup to the grid boosted the total harmonics distortion up to 15%.

Grid-connected PV array systems are usually installed to enhance the performance of the electric grid by improving the voltage profile of the grid. However, if the PV penetration is high, the PV array systems impose negative impacts on the electric grid as reactive power and harmonic distortions are being generated from the PV inverter. As the penetration of the PV array systems increases, the reactive power and voltage distortion will increase too; thus, with the intention of ensuring the power quality of the network, it will be necessary to initiate voltage harmonic filtering in order to achieve acceptable power quality and also greater efficiency.

References:

- [1] Hatziaargyriou N, Asano H, Iravani R, Marnay C. Microgrids. *Power and Energy Magazine, IEEE*. 2007;5:78-94.
- [2] Hepbasli A. A key review on exergetic analysis and assessment of renewable energy resources for a sustainable future. *Renewable and Sustainable Energy Reviews*. 2008;12:593-661.
- [3] Mitra I, Degner T, Braun M. Distributed Generation and Microgrids for Small Island Electrification in Developing Countries: A Review. *SESI JOURNAL*. 2008;18:6-20.
- [4] Hawkes AD, Leach MA. Modelling high level system design and unit commitment for a microgrid. *Applied Energy*. 2009;86:1253-65.
- [5] Manfren M, Caputo P, Costa G. Paradigm shift in urban energy systems through distributed generation: Methods and models. *Applied Energy*. 2011;88:1032-48.
- [6] Lasseter RH. Microgrids and Distributed Generation. *Journal of Energy Engineering*. 2007;133:144-9.
- [7] Chintavee A, Ketjoy N. PV Generator Performance Evaluation and Load Analysis of the PV Microgrid System in Thailand. *Procedia Engineering*. 2012;32:384-91.
- [8] Tumilty RM, Brucoli M, Burt GM, Green TC. Approaches to Network Protection for Inverter Dominated Electrical Distribution Systems. *Power Electronics, Machines and Drives, 2006 The 3rd IET International Conference on 2006*. p. 622-6.
- [9] Kotamarty S, Khushalani S, Schulz N. Impact of distributed generation on distribution contingency analysis. *Electric Power Systems Research*. 2008;78:1537-45.
- [10] Fang G, Iravani MR. A Control Strategy for a Distributed Generation Unit in Grid-Connected and Autonomous Modes of Operation. *Power Delivery, IEEE Transactions on*. 2008;23:850-9.
- [11] Adamopoulou A, Früh WG, Samarakou M. The Contribution of a PV Inverter in a Microgrid. In: Bourkas P, editor. *Power and Energy Systems - 2011*. Crete, Greece ACTA Press; 2011.
- [12] Adamopoulou A, Samarakou M, Früh WG. A Faster Model of PV Array System Implemented on MatLab-Simulink Environment. In: Angeli C, editor. *Applied Simulation and Modelling - 2011*. Crete, Greece ACTA Press; 2011.
- [13] IEEE Recommended Practices and Requirements for Harmonic Control in Electrical Power Systems. *IEEE Std 519-1992*. 1993:0-1.